



The Primer

An Overview of Airless Sprayers

Information on Basic Components, Spray Techniques and Safety



PROVEN QUALITY. LEADING TECHNOLOGY.

The Primer

An Overview of Airless Sprayers

PROVEN QUALITY. LEADING TECHNOLOGY.



Contents

- Contents 1**
- A World Leader in Fluid Handling Systems 2
- The Graco Advantage 3
- The Basics. 4**
- Architectural Coatings 6
- Advantages of Airless Sprayers 8
- Key Components of an Airless Sprayer. 10
- Airless Spray Tips 12
- How Airless Sprayers are Rated. 18
- Selecting A Sprayer 20
- Spray Techniques 21
- Summary 26
- Beyond the Basics 27**
- Sprayer Motors 28
- Pumps. 31
- Pressure Control 37
- Airless Spray Guns 38
- Accessories. 39
- Maintenance 40
- Safety 43
- Accident & Near Miss Reporting 48
- Glossary 49

A World Leader in Fluid Handling Systems

Founded in 1926, Graco is the world leader in fluid handling systems and components. Once a quiet family-owned business, Graco Inc. has become the world's premier manufacturer of fluid handling equipment and systems.

Graco equipment squeezes tomato paste onto millions of frozen pizzas; pumps oil and lubricating fluids into millions of cars; applies paint to homes, business and industrial installations; and helps give cars made around the world their high-gloss finishes.

Working closely with specialized distributors, Graco offers systems, products and technologies that set the quality standards in a wide range of fluid handling applications. Graco applications include spray finishing and paint circulation, lubrication, sealants and adhesives along with power application equipment for the contractor industry. Graco's ongoing research investments in fluid management and control will continue to provide innovative solutions to a global market.

Contractor Equipment Division

Graco's Contractor Equipment Division (CED) offers a complete product line for the professional contractor including:

- Electric-powered airless sprayers
- Gas mechanical sprayers
- Gas hydraulic sprayers
- HVLP fine finish sprayers
- Texture sprayers
- Air-Assisted airless sprayers
- Road and parking lot stripers
- Sport field stripers
- Roofing spray equipment
- Pressure washers
- Air powered corrosion control equipment
- A full line of parts and accessories, such as spray tips, guns and hoses

The Graco Advantage

Graco Inc., is recognized as the quality leader in the airless sprayer market. As the industry leader, Graco offers the largest line of quality painting equipment and accessories in the world. Graco has achieved high market acceptance—painting contractors have known and trusted the Graco name for over 40 years.



Graco works hard to meet the needs of today's painting contractor. Ongoing improvement to existing products and continuous innovation are key factors in developing premier products. Graco invests more money on research and development than competitors and it shows in the quality and durability of Graco airless spray equipment.

In addition to Graco's experience in the airless market and the company's commitment to research and development, is the genuine effort to educate professional contractors about the advantages of airless spray equipment.

Ongoing support is always available and is simply a phone call away with Graco's excellent

customer service and technical assistance. Add to this Graco's sales and training efforts and it is clear there is more to Graco than great products. It is great people that make Graco the brand-of-choice among professional painting, texturing and striping contractors.



The Primer

The Basics

- *What four basic components does virtually every coating contain?*
- *What determines a fluid's flow rate in an airless spray system?*
- *What are three major advantages of using an airless sprayer?*
- *How are airless sprayers rated by equipment manufacturers?*
- *What are the four major components of every airless sprayer?*
- *Explain how the last three numbers of a spray tip tell you the orifice size and spray pattern fan width?*
- *Why do spray tips wear and how does that affect your production and job costs?*
- *Why is the 50% overlap method the best way to get an even, quality spray finish?*
- *What are two spray technique mistakes many new contractors make?*

Currently, there are fewer than 1,000 paint manufacturers in the United States manufacturing over 600 million gallons of architectural coatings annually.

Architectural coatings are protective and decorative coatings used to coat anything from water towers to homes. The majority of coatings are sold at paint stores, generally to professional painting contractors.

Virtually every coating contains four basic components:

- **Binder, Resin, or Polymer**—holds together the other components prior to application and forms a protective film on the surface (the surface is also called a substrate) to which the coating is applied. Binders can be oils, varnishes and proteins.
- **Pigment**—fine solid particles that hide the surface providing decorative colors and sometimes corrosion resistance. Raw umber, a type of iron ore, is used extensively as a pigment and is olive green in color.
- **Solvent**—helps the flow of the coating material and aids in application. For example, water is a solvent for sugar. However, in many coating formulations, a chemical referred to as a solvent, may not be dissolving anything, but simply diluting or thinning the formulation.
- **Additives**—in general, manufacturers put additives into coatings for one or more reasons, including aiding in manufacturing, enhancing application characteristics, or improving the properties of the coating once it is cured. For example, some additives help prevent mildew from forming once the coating has cured.

Paints and other coatings are rated by the volume of solids they contain. While virtually everyone in the architectural coatings industry refers to the “low,” “medium,” and “high” solid content of coatings, there are no set amounts or limits placed on these categories. A typical set of values for coatings is:

- Low Solids = 20-30% solids
- Medium Solids = 30-50% solids
- High Solids = 50% or more solids

All coatings contain solids which are abrasive. Through normal use the spray tip and parts of the pump will show wear.

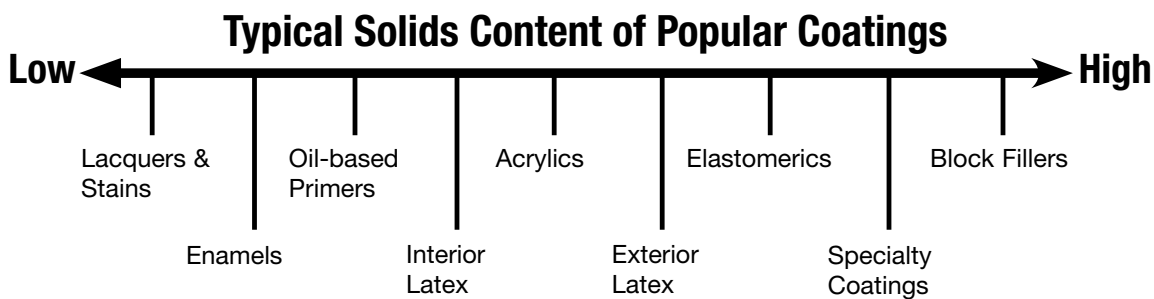

Keeping in mind the typical amount of solids found in coatings (low, medium, or high), allows an easy method for displaying the solids content of popular architectural coatings.

Defining Airless

Airless spray atomizes, or breaks up fluid into small droplets without the use of compressed air. In an airless system, fluid is pumped under high pressure through a spray tip. The **tip size** and **pressure** is what determines the material flow rate.

The tip also creates the fan pattern. In contrast, air spray systems inject compressed air into the fluid stream of paint to achieve atomization.

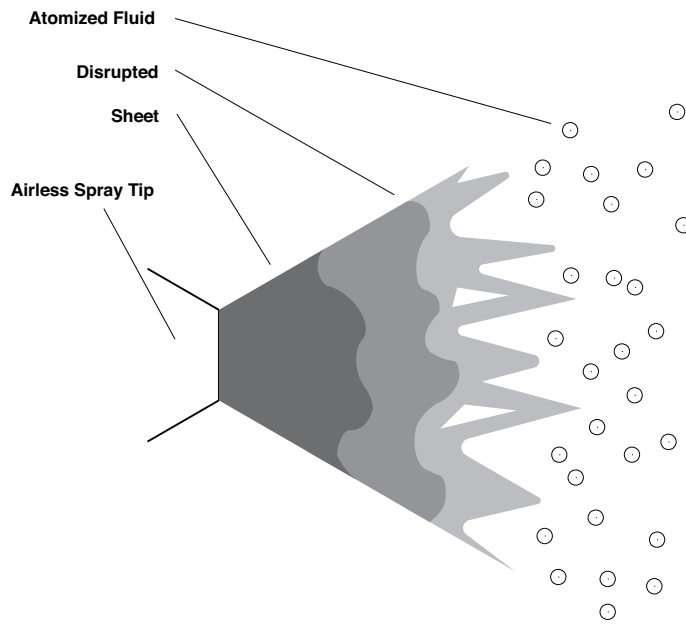

In airless spray, the fast moving high-pressure liquid stream provides the energy necessary to overcome the fluid's viscosity (resistance to flow) and surface tension (a force that bonds the surface of a liquid together) to form a fine spray.

In the depiction of spray from a gun, high pressure forces fluid through a small nozzle (spray tip). The fluid emerges as a solid stream (sheet) at a high speed. When the solid stream hits the air, it becomes disrupted. This disruption breaks the fluid into fragments initially, then ultimately very small droplets that form the spray pattern.

Advantages of Airless Sprayers

Airless sprayers provide an easy and economical way to apply coatings.

Professional contractors prefer to use airless sprayers for several reasons, the most popular being:

- **Speed**—airless spraying is faster, thus, more jobs can be completed in less time, using less labor. Airless spraying is up to 4 times faster than brushing or rolling.
- **Quality**—airless sprayers produce an even coat of paint on all types of surfaces, leaving a high quality finish.
- **Versatility**—airless sprayers can be used for a wide range of coating materials, including interior and exterior jobs, and can easily be transported from job site to job site.

Did you know?

If you took a shower today, you used a very simple airless spray.

Research conducted by the Painting and Decorating Contractors of America (PACE), an association of painting contractors and related industry professionals, indicates that airless spraying can save painters between 50% and 75% of their painting time. Airless spray is:

- At least **4 times faster** than brush applications
- At least **2 times faster** than roller applications

Using a brush or roller application might seem cost-effective in the short-term, but in the long-run labor can cost at least twice as much!

Airless Spray for Uniform Coverage

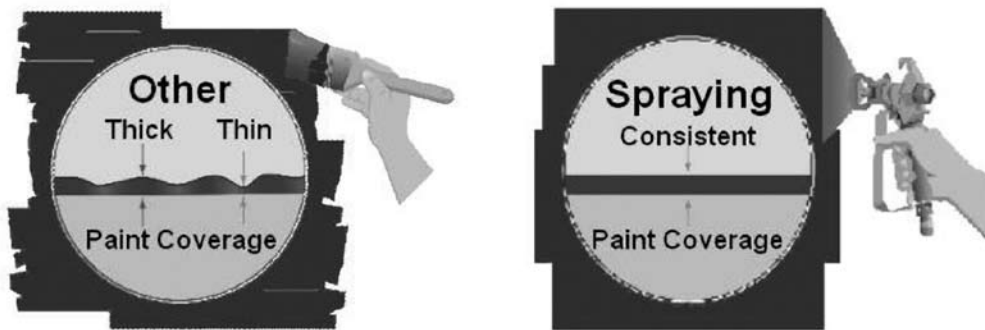

It is important to consider how much faster spraying is compared to other methods. Equally important to your customer is how spraying gives a consistent quality finish, even over rough surfaces.

Airless spraying allows you to:

- Finish jobs quicker
 - Finish within short weather windows
 - Stay on a job site from start to finish, saving set-up labor
- Complete more jobs with less labor (fewer people headaches)
- Provide a consistent mil build so coatings perform better
- Apply a smooth quality finish

The Basics . . . Key Components of an Airless Sprayer

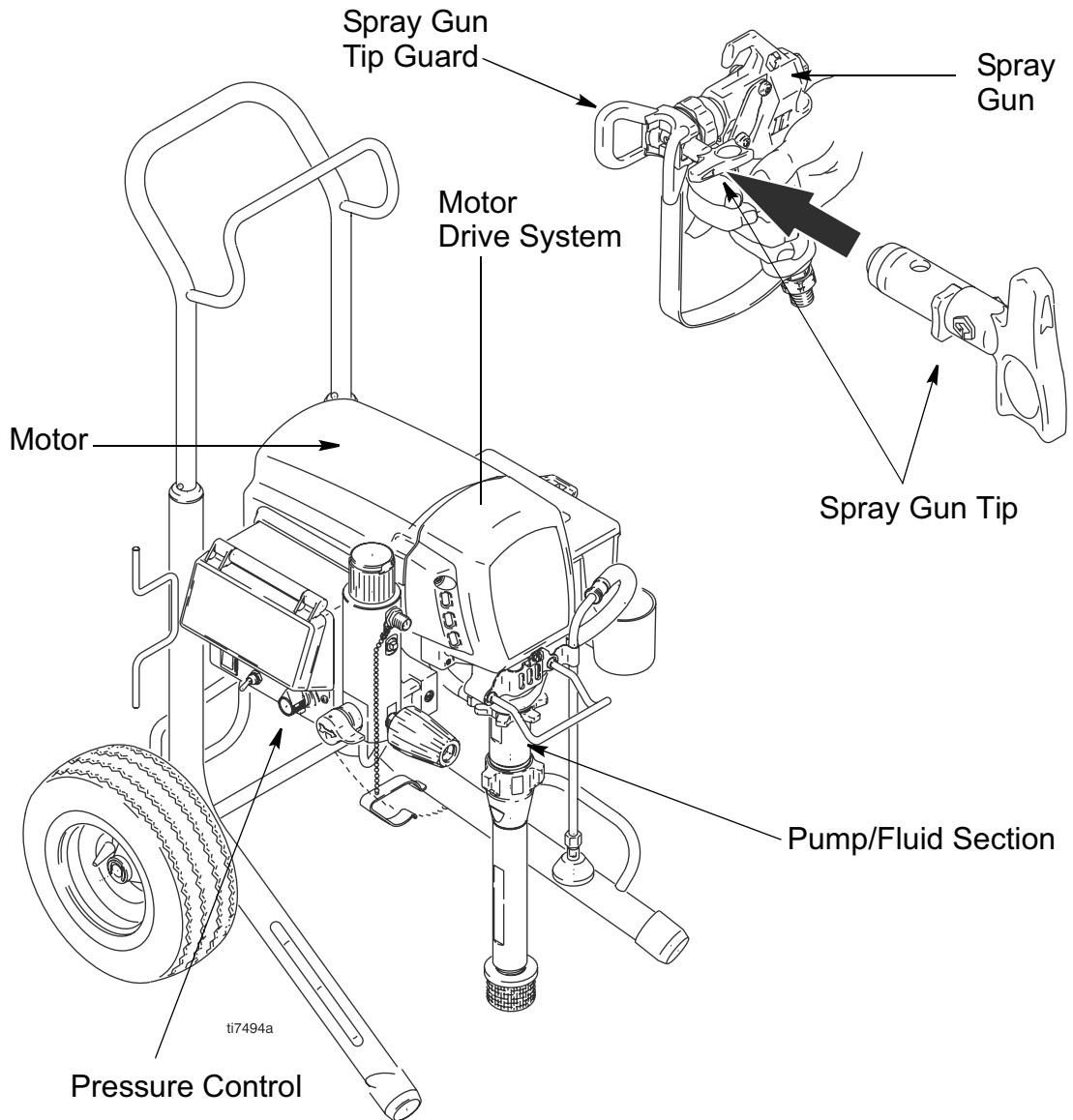

The Basics . . . Key Components of an Airless Sprayer

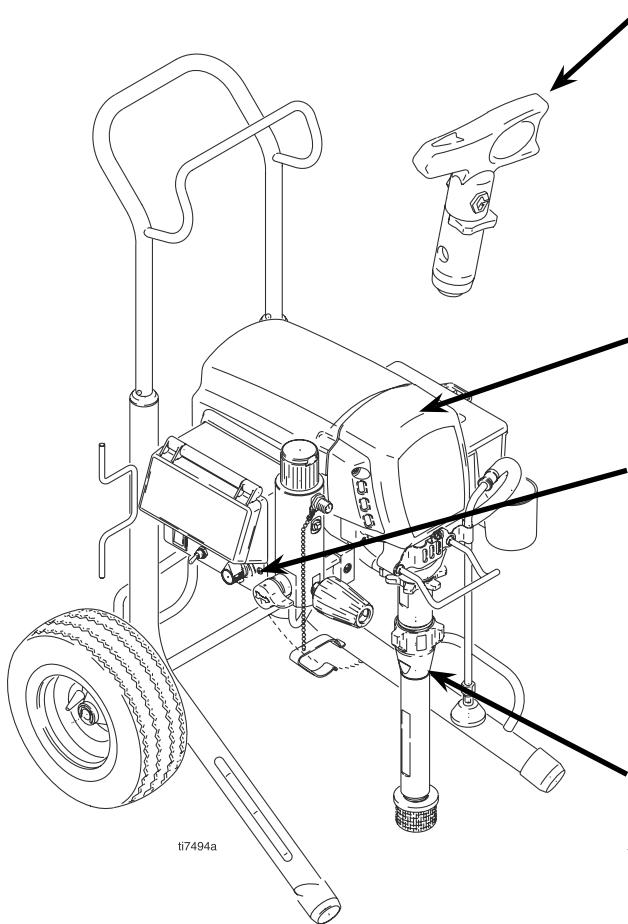

Spray Gun Tip

- Controls the amount of fluid sprayed by using different orifice sizes
- Orifice shape determines the spray pattern.
- Many Graco tips can be turned by hand to blow out clogs

Motor & Drive System

- A heavy duty system that drives the pump

Pressure Control

- Used to regulate the fluid pressure delivered from the pump
- In quality units the pressure control turns off the drive system at a set pressure to reduce wear on your system

Pump

- Also called the Fluid Section
- Delivers a steady stream of high pressure fluid through the hose to the spray gun

*Did you know?
The pump is often called the heart of the system. Many contractors refer to a sprayer unit as “the pump”. Most consider the pump to be the most important component of the sprayer.*

This, small, exchangeable part plays a big role. An airless spray tip:

- Determines the fluid flow = the amount of coating applied
- Determines the spray pattern (fan width)

Selecting the correct spray tip for the job is an important decision.



Graco Tips

All Graco tips are made out of the highest grade of **tungsten carbide**, the most abrasive-resistant material used in the manufacturing of airless spray tips. Because each tip has its own particular use in the market place, Graco offers the following spray tip selection:

Reverse-A-Clean® (RAC) Most widely used reversible tip on the market and can be used for a variety of coatings from lacquers to mastics. Reversible tips are an ideal way to eliminate downtime. With a reversible tip, clogs are cleared easily and contractors can change tip sizes in seconds, without removing the tip guard and housing. Reversible Tips are available in over 90 sizes and are rated at pressures up to 5000 PSI (blue or black handle).

Fine Finish SwitchTip This tip incorporates a two-stage atomization process and creates a soft, feathered spray pattern. It allows the user to do fine finish work with an airless pump, this is faster than air spray or HVLP. Fine finish tips are ideal for lacquers, varnish, stains, and high finish enamels (green handle).

WideRAC™ SwitchTip This tip covers double the surface area in half the time with extra wide 24 inch (61 cm) pattern. WideRAC tips are made for higher production, new construction applications which require larger airless spray guns.

WideRAC Conversion	
RAC 5 or RAC X	WideRAC
414 or 515	1221 or 1223
417 or 517	1223 or 1225
419 or 519	1225 or 1227
421 or 621	1229 or 1231
523 or 623	1233 or 1235
525 or 625	1235 or 1237

When you use WideRAC, be sure to increase the flow rate of the tip to ensure the same mil build and rate of application (arm speed). Also, make sure your airless sprayer can support the larger tip size.

Heavy Duty SwitchTip This tip is used for heavy coatings which require higher pressures to atomize. Heavy duty tips are still reversible, but add an extra thick twist lever to allow rotation in very sticky coatings such as coal tars and mastics (gray handle).

LineLazer™ & FieldLazer™ SwitchTip Used with the LineLazer & FieldLazer Spray Units. Regular tips are designed for an overlapping spray technique. The LineLazer & FieldLazer tips are designed to provide a consistent pattern without soft edges to create clean, laser sharp lines (yellow handle).

Contractor™ Flat Tip Standard airless tip available in a variety of sizes that are less expensive to purchase than RAC tips. If plugging occurs, the tip must be removed from the gun and cleaned or replaced.

Fine Finish Flat Tip Sprays as fine a finish as the fine finish RAC but must be removed for cleaning when plugged. Typically, coatings used for fine finish applications plug easily (i.e., lacquers). Therefore, if this tip is used, it is recommended that a **Tip Filter Kit** be used as well.

Did you know?

Graco uses a color-coding system to identify tip types.

- *General SwitchTips are blue or black*
- *Fine Finish tips are green*
- *LineLazer and Field Marker tips are yellow*
- *Graco Heavy Duty tips are gray*

Breaking the Code

XXX - 515

First digit when doubled, is spray pattern fan width. A 515 has a 10-inch fan width when sprayed 12 inches from surface.

$$5 \times 2 = 10$$

Last two digits are orifice size in thousandths of an inch, a 515 has a 0.015 inch orifice.

Rating Spray Tips

Spray tips are rated in terms of **Gallons Per Minute (gpm)**. The amount of paint that flows through the sprayer onto the surface depends on the tip size and pressure setting.

- Size the spray tip according to the job and the flow rate of the sprayer. Make sure that the sprayer can support the tip flow rate.
- Consider the paint/coating that will be sprayed - lacquers, stains, and enamels are light coatings that are sprayed with small tips, while exterior latex paints are much heavier coatings that require larger spray tips.
- Multiple spray guns can be used with one sprayer. Make sure the combined flow rate of all the tips added together does not exceed the maximum sprayer flow rate.

Recommended Tip Sizes for Common Coating Materials

Lacquer or Stain	.009 to .013
Oil Base Paint	.013 to .015
Latex Paint	.015 to .019
Heavy Latex Paint & Smooth Elastomeric	.021 to .025
Elastomeric & BlockFiller	.025 to .035+



oroughly before use. May be applied by brush or roller. For spray application, use .015" tip. Apply when the surface or air temperature is below 50°F and above 40°F for normal drying.

Many paint manufacturers will specify recommended spray tip sizes directly on the container or product specification sheet.

Which tip puts out more paint,

286-517 or 286-317?

The answer . . . each tip has the same size orifice (.017") that allows the same flow of material, so the output is the same.

But . . .

*fan width) and the mil build (thickness) is less
The 517 tip sprays the paint in a larger area (10" than
the 317 tip (6" fan).*

Tip Wear

Tip wear can cost you hundreds of dollars in wasted paint and labor. Choosing the right spray tip is essential for ensuring a quality finish no matter which coating material is being sprayed. **All** spray tips will wear with normal use. It is important to understand the wear effect coatings have on spray tips. All coatings contain solids that are abrasive; some are more abrasive than others. For example, latex paint may be very abrasive because of the solids used in the manufacturing process. The level of abrasiveness often depends upon how finely the solids have been ground. Graco tips are made out of the highest grade of tungsten carbide, the most abrasive resistant material used in manufacturing airless spray tips.

Effects of Tip Wear

When a tip wears, the size of the tip orifice increases and the fan width decreases. Tip wear affects the spray pattern. If the fan size has lost 25% of its original size, then it is time to replace the spray tip. Continuing to spray would simply result in a poor quality spray job, and a substantial waste of paint and labor.

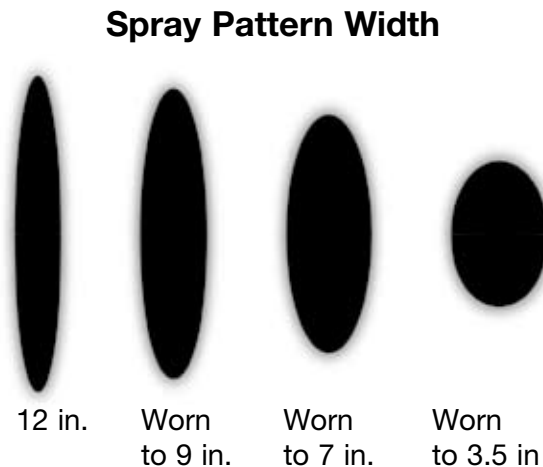

Example: When a tip that had a 12-inch fan pattern is reduced to a 9-inch fan when worn, it will output 40% more paint on 25% less area. Overlapping to achieve a consistent mil thickness becomes impossible. The chart above illustrates the effects of a worn tip on a spray pattern.

Tips for extending the life of spray tips:

- *Spray at the lowest pressure necessary to atomize material*
- *Strain the coating material prior to spraying, using a nylon strainer bag*
- *Use correct size filters*
- *Clean filter after each use*
- *Use a soft bristle brush to clean tips*

Using a worn tip wastes paint and labor

Assume that paint costs \$10 per gallon, labor costs \$18 an hour, and the contractor sprays 5 gallons of paint per hour. If the contractor is using a worn tip (a 12 in. fan width worn to 9 in.) he will spend an additional \$24.50 in wasted paint and labor per hour. If the painter continues to use the worn tip it will cost him about \$200 per day!

If abrasive materials are sprayed at too high of pressure, the spray tip will wear a lot faster, wasting both paint and money.

Greater Pressure = Greater Wear.



Turn down the pressure as low as it can go while still spraying a good spray pattern to reduce your tip and pump wear. Turning down the pressure also saves paint by reducing overspray.

How Airless Sprayers are Rated by Manufacturers

Airless sprayers are typically rated using these methods:

- Gallons per minute (**gpm**)
- Pounds per square inch or the maximum pressure (**psi**)
- Horse power (**hp**)
- Maximum tip size

gpm—(gallons per minute) a flow rate measurement associated with the pump’s output capacity and the tip orifice (hole) size. **There is no industry standard for rating a sprayer’s output capacity.**

psi— (pounds per square inch) a pressure measurement.

The pressure rating (e.g., 3300 psi) is the **maximum working pressure** of the sprayer. That is, the maximum amount of pressure the sprayer is able to build. However, the pressure at the tip does not equal the maximum working pressure. Hose length, tip size, the type of coating being sprayed, and even the filters impact the amount of pressure available at the tip while spraying.

Typical maximum airless sprayer pressure ratings:

- 2800 psi
- 3000 psi
- 3300 psi
- 4000 psi

Typical atomization pressures needed for airless applications:

- 800-1100 psi for lacquers
- 1200-1800 psi for stains
- 2000+ for latex coatings

hp—(horse power) a performance rating for the sprayer’s motor or engine. There are a variety of motor types, operating speeds and torque capabilities available. This makes horsepower a confusing rating method for distributors and end-users alike. Some contractors prefer to have the biggest motor available because they believe it means more power and longer sprayer life. This is not necessarily true, the motor and sprayer should be matched to the jobs requirements.

Maximum Tip Size—a rating that indicates the largest tip size (i.e., orifice) a sprayer is capable of supporting, while maintaining a good spray pattern. The maximum tip size will depend on the type of coating being sprayed and the amount of pressure needed to atomize the coating.

*Did you know?
All Graco sprayers are rated for
maximum tip sizes using the
most common coating material,
latex paint, at 2,000 psi.*

Selecting A Sprayer: Eight Questions To Ask

What types of materials will you spray? Now and in the future?

The types of materials you spray will determine the size of the tips you use. If you plan to spray a variety of materials you have to consider buying a sprayer with more versatility.

How many gallons per week will you spray?

Purchasing a part-time sprayer to do a full-time job has disappointed many contractors. In the long run, saving money on a sprayer that is inadequate for the job, or not durable enough, will cost a lot in lost labor.

What power sources are available? Will most jobs be indoors or outdoors?

Your answers will help choose a unit family (gas, electric, or compressed air) based on power sources alone.

What types of surfaces will you be spraying?

Will you be spraying on drywall, exterior siding, or concrete? You have to consider the tip sizes needed as well as the quality of finish required in order to choose the best sprayer for the job.

How many spray guns will you use at one time, now and in the future?

If you plan to use more than one gun at a time, then you have to purchase a unit that has the ability to handle multiple guns.

What types of jobs will you bid?

Each job has its own requirements. New construction, residential work, and commercial jobs all vary in terms of: coatings used, crew size needed, and power sources available.

What hose lengths will you use?

Hose length depends on the job site, material being sprayed, tip size, and hose diameter. Your sprayer must be able to support the length of hose. Most Graco sprayers use DC motors, which are able to support longer extension cord lengths than either AC or universal motors.

How much do you want to spend on a sprayer?

Buying a sprayer is an investment. You do not want to over-buy or under-buy. Keep in mind the cliché, “You can pay now or pay later”. Downtime resulting from an undersized, overworked sprayer or poor quality equipment can quickly wipe out any savings from the initial low purchase cost of the sprayer.

A good spray pattern indicates that the paint or coating is completely atomized and distributed evenly on the surface. Several techniques help determine the quality of the spray pattern and the quality of the finish.

- Adjusting the pressure
- Aiming of the spray pattern
- Movement of the spray gun

The following techniques ensure a long-lasting quality finish.

Adjusting the pressure for spraying

It is best to spray at the lowest pressure that completely atomizes the coating. The pressure control should be set at a low-pressure setting and slowly increased until the paint is completely atomized. If the spray pattern has **fingers** or **tails**, then the pressure should be increased.

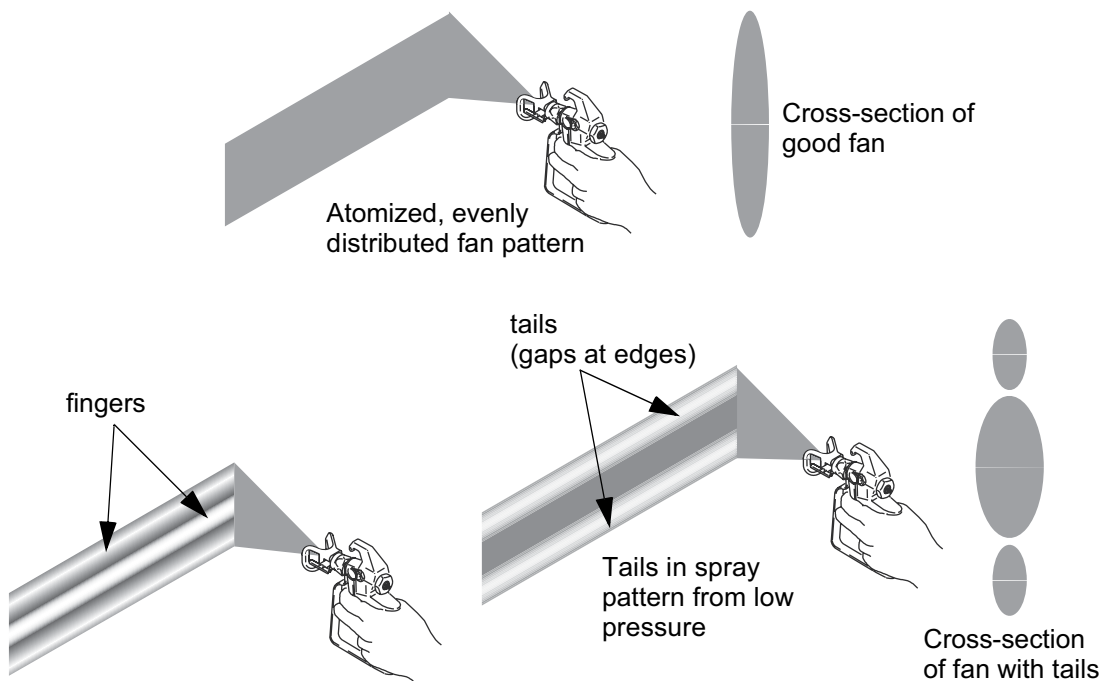

Note: If the maximum pressure of the sprayer is not enough to achieve a good spray pattern, a spray tip with a smaller orifice should be used. To test the quality of the spray pattern, test patterns should be sprayed on scraps of cardboard or other waste material.

Aiming the Spray Pattern

The spray gun should be held approximately 12 inches (30.5 cm) from the surface, and aimed straight (both horizontally and vertically) at the surface. Extremely large tips will require you to move further away to achieve a good spray pattern.

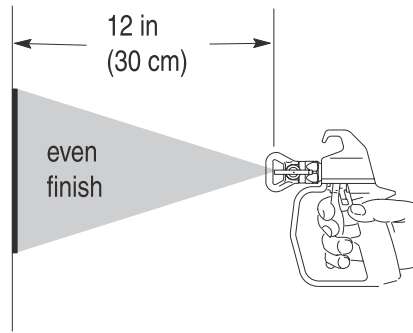

Spray gun aimed straight at surface

Tilting the gun in one direction or the other to spray at an angle causes an uneven finish.

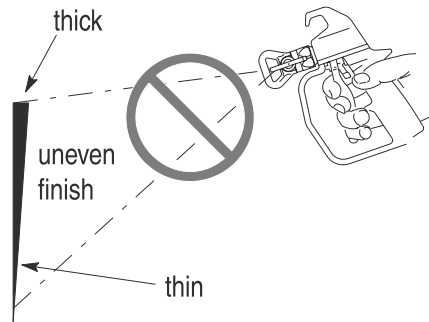

Spray gun tilted downward or upward will produce an uneven finish

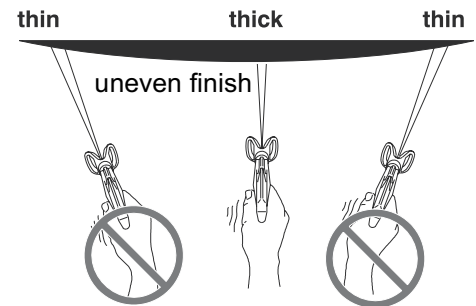
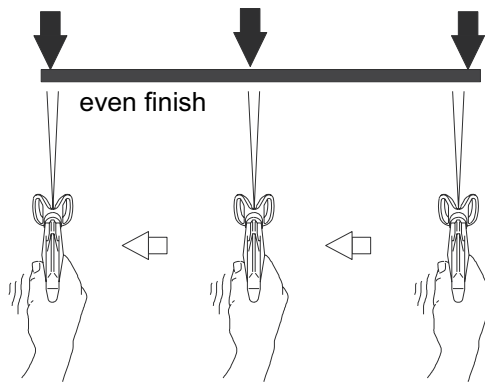

The spray gun should move across the surface with the wrist flexed to keep the gun pointed straight at the surface. "Fanning" the gun to direct the spray at an angle will cause an uneven finish.

Triggering Technique

The spray gun should be triggered after beginning the stroke (also called the **lead** stroke) and released before ending the stroke (also called the **lag** stroke). The gun should move during both the trigger squeeze and trigger release. This technique prevents blotches of thick coating at the beginning and end of each stroke.

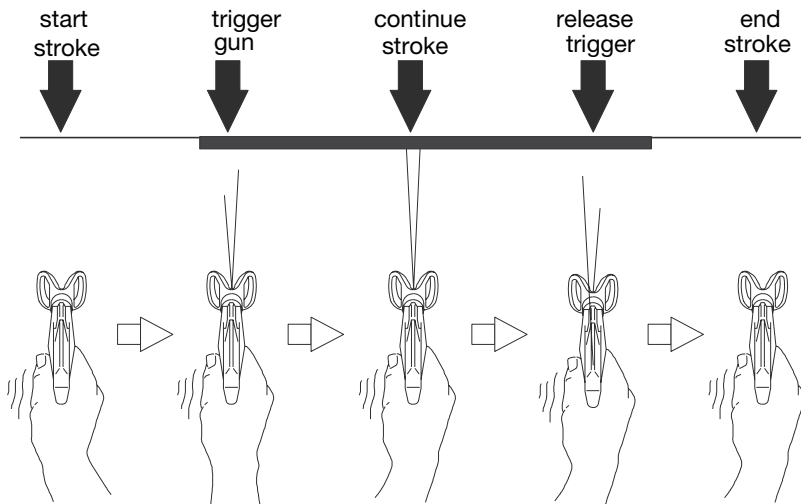

Overlapping Technique

This technique ensures that an even amount of coating has been sprayed onto the surface. The spray gun should be aimed so that the tip points at the edge of the previous stroke, overlapping each stroke by 50%. To maximize efficiency when spraying on broad, open surfaces, like ceilings and bare walls, the outside edges of walls should be sprayed first. The middle can then be sprayed quickly, requiring less precise strokes.

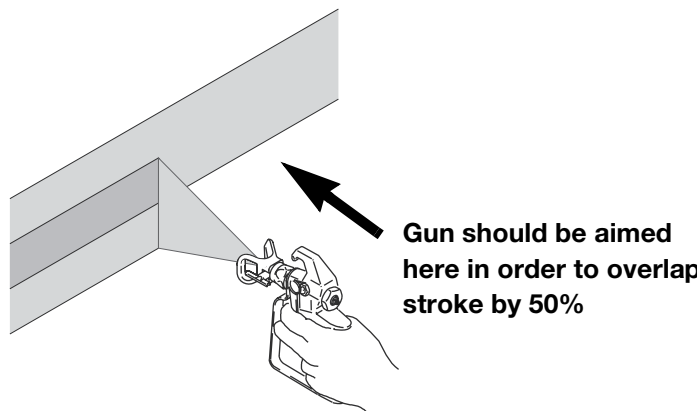

Painting Inside Corners

When spraying corners the gun should be aimed into the corner, spraying along the corner, rather than spraying back and forth across the corner.

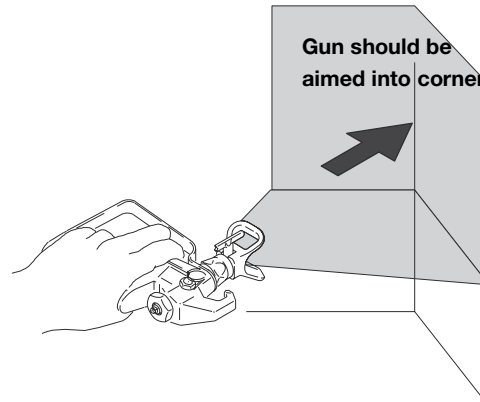

Controlling the Thickness of the Coating (Mil Build)

The key to proper coverage is controlling the coat thickness. Here are some helpful hints to ensure proper coverage and a quality finish:

Do not adjust the pressure to make the coat thicker or thinner. The pressure should be adjusted to the lowest pressure with a good spray pattern.

If the coating is too thick or running down the surface, one or more of the following will help:

- Move the spray gun faster
- Choose a smaller tip orifice size; be sure the sprayer is rated to handle the size tip being used
- Choose a tip with a wider fan
- Make sure the spray gun is far enough away from the surface (about 12")

If the finish is not covering the surface, one or more of the following will help:

- Move the spray gun slower
- Choose a larger tip
- Choose a tip with a narrower fan width
- Make sure the spray gun is close enough to the surface (about 12")

Common Spray Technique Errors

Turn It Down

It is easy to just crank up the pressure control to the maximum and slap on the material. For professional results, turn down the pressure as low as you can without getting tails. You will:

- **Reduce wear on your pump**
- **Reduce wear on your spray tip**
- **Spray a more consistent even finish**
- **Reduce the amount of overspray (wasted paint)**

Trigger The Gun!

It is easy to just pull the trigger and keep moving up and down or side to side, overlapping and moving down the wall spraying constantly. If you are not triggering the gun every time you change directions you will have at least double the mil thickness in every spot you change directions. In the right light or over time, your customer may be able to see these heavy areas. As explained earlier, you should trigger the gun on each stroke and be moving into and out of each trigger pull.

Basics Summary: Questions Answered

What four basic components does virtually every coating contain?

- Binder, Pigment, Solvent, Additives

What determines a fluid's flow rate in an airless spray system?

- Tip orifice size and pressure

What are three major advantages of using an airless sprayer?

- Speed, Quality, Versatility

How are airless sprayers rated by equipment manufacturers?

- Gallons per minute, Maximum pressure in psi, Horse Power, Maximum tip size

What are the four major components of every airless sprayer?

- Motor and Drive System, Spray Gun Tip, Pressure Control, Pump

Explain how the last three numbers of a spray tip tell you the orifice size and spray pattern fan width.

- First digit when doubled is the fan width
- Last two digits are the orifice size in thousandths of an inch

Why do spray tips wear and how does that affect your production and job costs?

- Coatings have abrasive materials in them and wear tips under high pressure
- A worn tip reduces the fan width and increases fluid flow, increasing labor and paint costs

Why is the 50% overlap method the best way to get an even quality spray finish?

- Spray tips are designed for a 50% overlap so you get a smooth even finish with no visible lines

What are two spray technique mistakes many new contractors make?

- Spraying at too high of a pressure, not triggering the gun properly at the start and stop of each stroke



The Primer

Beyond the Basics



Sprayer Motors

Sprayer pumps can be operated from three different power sources: electric motor, gas engine, or compressed air. In all electric and gas sprayers, the motor or engine creates a rotating motion that is transferred to the drive source of the fluid pump. Most of Graco's sprayers use crankshafts and connecting rods to convert the rotating motion into the reciprocating action of the fluid pump. Hydraulics can also be used to transfer power from the source to the pump in the case of hydraulic sprayers.

In compressed air motors, the flow of air through the motor causes the motor piston and rod to move up and down. This reciprocating motion is then transferred from the motor connecting rod to the fluid displacement rod in the pump.

Electric Sprayers

There are three types of motors available on airless sprayers: **AC**, **DC** and **Universal**. The following chart compares the advantages and disadvantages of each type of motor.

Motors	Advantages	Disadvantages
<i>AC</i>	A long life motor when used in controlled conditions.	Need constant, continuous power supply to perform properly. Long extension cords and generators often cause overheating which could permanently damage the motor. Maximum length of extension cord is 100 ft.
<i>Brushless DC</i>	A long life motor in a variety of conditions. It is more forgiving of power fluctuations because it can run at variable speeds. Allows the use of longer extension cords (up to 300 feet) and generators.	A heavier motor than an AC. Most expensive motor compared to AC or DC motors.
<i>DC</i>	The DC motor is more forgiving of power fluctuations because it can run at variable speeds. Allows the user to run longer extension cords (up to 300 ft.) and generators.	DC Motors are heavier and more expensive.
<i>Universal</i>	Price is the big advantage of Universal motors—they are less expensive to manufacture than either AC or DC motors.	Although fan cooled, Universal motors are not totally enclosed. They have the shortest life expectancy because they run at 10,000 – 20,000 RPM (3 - 5 times faster than AC or DC motors).

DC Motor Technology Changes

In recent years DC motor technology has improved. They:

- deliver higher output – increases flow rates
- have a much lower amp draw – shorter cords, fewer nuisance trips
- are smaller and lighter – easier to move
- run cooler = longer life
- are brushless – no open sparking
- have more horsepower – motors don't work as hard, longer life
- are TEFC (totally enclosed fan cooled) – Protects components from dirt, dust and overspray

Gas Engines

A direct drive **gas engine** develops the horsepower to drive the pump and the electrical energy to power the clutch. This is known as a “direct drive” system.

A **hydraulic unit** uses a gas engine to drive a hydraulic pump. The hydraulic pump draws hydraulic oil from a reservoir and pumps it to the hydraulic motor. This causes the hydraulic motor to reciprocate and power the fluid pump. This is known as a “hydraulic” system.

The Proof is in the Pump

There is much discussion about pumps in the sprayer market; after all, most consider the pump the most important component of a sprayer. Contractors often refer to a sprayer unit simply as “the pump.” There are two general types of pumps offered in the airless sprayer market: **diaphragm** and **piston**. The following section describes the advantages and disadvantages of each type of pump for airless applications. All Graco airless sprayers use piston pumps.

Piston vs. Diaphragm

	Advantages	Disadvantages
Diaphragm Pump	<ul style="list-style-type: none"> • Good, tight pressure control across a full range of pressures • High free-flow rates, good for high-volume transfer of fluids for texture applications, water, and so forth • Lower initial purchase price 	<ul style="list-style-type: none"> • Runs continuously • Higher maintenance costs • Difficult to prime • Cavitates easily—air is introduced into the system possibly causing erratic flow or spitting. This usually is because the pump isn’t strong enough to move the coating material. • Poor performance with higher viscosity fluids as mentioned above • Must be kept clean (small moving parts) • Requires constant maintenance • Hydraulic oil leakage • Frequent diaphragm failure
Piston Pump	<ul style="list-style-type: none"> • Pumps higher-viscosity coatings with ease • Provides higher pressure at common tip sizes • Better atomization • Allows the use of longer hoses • Better withstands hard use • Lower maintenance costs • Easy to repair • Primes easier • Runs only on demand 	<ul style="list-style-type: none"> • Higher initial purchase price, but less expensive to maintain • Some pressure fluctuations, noticeable at low-pressure settings

How a Diaphragm Pump Works

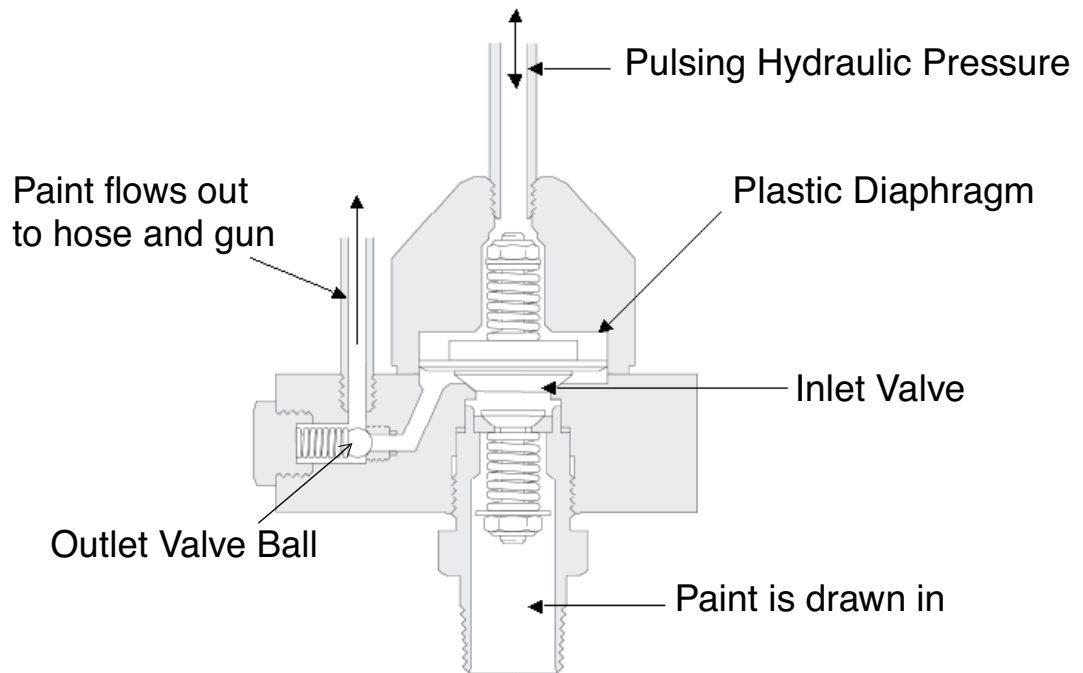

Independent research indicates that over 85% of professional contractors prefer piston pumps because they . . .

- Last longer
- Perform on-the-job better
- Are more durable than diaphragm pumps
- Require less maintenance

A diaphragm pump uses the sprayer's motor to create pulsing hydraulic pressure (a hydraulic system using oil) to drive the pump. During the upstroke or intake stroke, the diaphragm is pulled up, creating a partial vacuum within the paint chamber. The vacuum pulls the inlet valve open and the outlet valve is pushed closed by the spring and paint pressure in the hose. Paint is then drawn into the paint chamber.

On the down-stroke or pressure stroke, the inlet valve is closed and the outlet valve is forced open as paint is discharged to the sprayer hose. Diaphragm pumps have a relatively small displacement volume. The pump must run fast (about 1725 cycles per minute) to deliver a steady flow of coating material.

How a Piston Pump Works

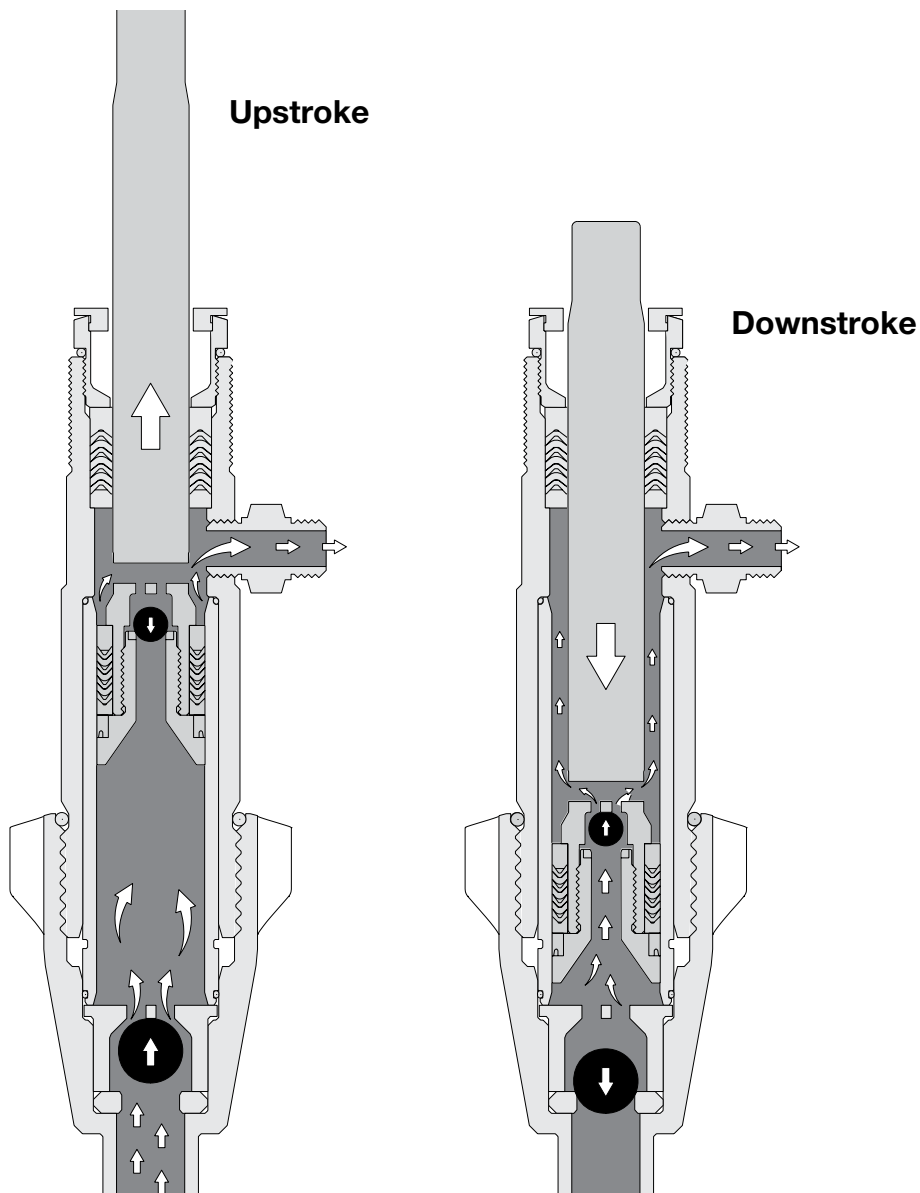

The **double action displacement pump** is a reciprocating pump with two ball checks (inlet and outlet ball checks) that control the flow of fluid through the fluid section. The **displacement rod** connects the pump's internal components to the drive system. The rod moves up and down with the action of the drive system and motor. Fluid is loaded on the upstroke and displaced on both the upstroke and downstroke, Displacing fluid on both the up and down strokes ensures an even flow of fluid to the hose and gun.

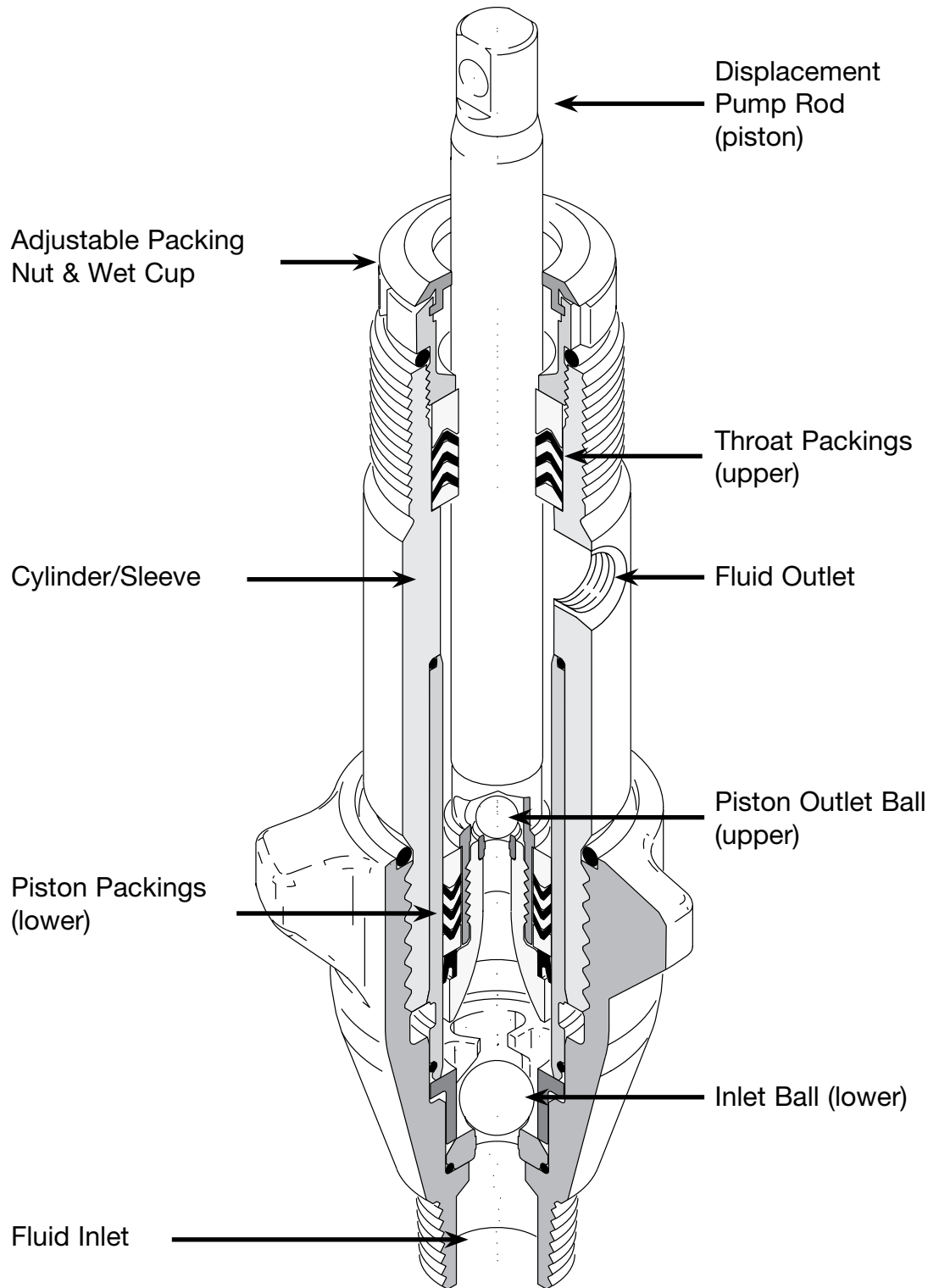

The general purpose of the packings is to create a seal and direct fluid flow. There are two sets of packings, **throat** and **piston**:

Throat packings seal the displacement rod to the top of the pump cylinder. As the throat packings wear, there may be leakage into the **wet cup**. Leakage indicates that the **packing nut** must be tightened or that the throat packings, or other parts, should be replaced or serviced.

Piston packings create a seal inside the cylinder as the rod moves up and down (like a doctors syringe).

- On the upstroke fluid is drawn into the pump because a vacuum is created as the rod goes up. As the rod goes up, fluid is pushed out to the hose. The lower ball lifts and allows fluid to be drawn into the pump, filling the cylinder. The upper ball seals the opening to the lower section.
- On the downstroke the lower ball seals, the upper ball opens and the rod moving down displaces (the volume of the rod takes up space) fluid and forces fluid out to the hose.

This process allows fluid to be pumped to the hose on both the up stroke and down stroke, for more consistent pressure and fan pattern from the spray gun.

The **wet cup** is a reservoir that holds **Throat Seal Liquid (TSL)** and extends the life of the throat packings by preventing paint from drying on the displacement rod. Graco TSL™ is clear in color and specially formulated so it will not impact the finish of oil or water-based coatings, even if it is accidentally dripped into the coating material. Do not substitute oil for TSL.

When the throat packings no longer seal properly there will be fluid/paint leaking at the wet cup.

A little leakage might be ok; many contractors will tighten the packing nut. This allows them time to finish the job prior to servicing the packings.



Graco TSL™

Specially formulated to extend the life of throat packings and other components.

Pump Wear Parts

Wear parts are components in the fluid section that are designed to wear with use. Wear parts will need replacement or service during the life of the pump. Throat and piston packings are made to wear with use. This saves wear on the expensive **hard parts** of the fluid section (displacement rod, cylinders and sleeves). Replacing the packings right away when needed will save you time and money. Replacing packings in a service center takes little time, and the costs associated with repairs are much less than if the hard parts need replacing. The following parts should be checked periodically for wear:

- Displacement Rod
- Cylinder or Sleeve
- Throat and Piston Packings
- Balls (inlet & outlet) and Seats

Got Wear?

Changing the packings at the first sign of wear will prolong the life of the pump by preventing wear of the hard parts. The throat and piston packings and balls and seats are included in the packing kits available for each Graco sprayer.

ProConnect™

Graco's exclusive ProConnect system allows quick removal or installation of your pump lower, with no tools required. The pump can easily be switched out in minutes right on the job site.

ProConnect prevents down time and avoids expensive labor when repair is needed.

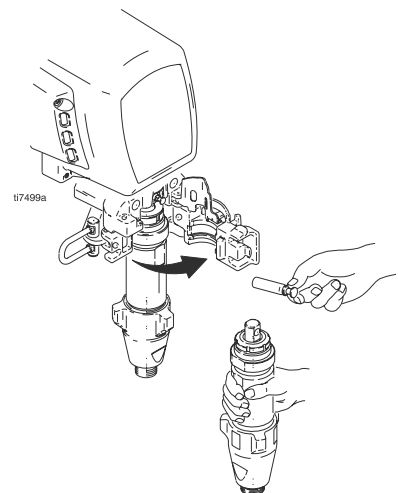

Pressure Controls

The purpose of the pressure control is to regulate the spraying pressure. There are two types of pressure controls: Mechanical and Electronic

Mechanical—a pressure control uses a micro switch to turn the motor on and off to maintain the desired pressure setting. The fluid pump runs until it reaches the set pressure—at this point the micro switch is activated and the motor shuts off. When the pressure decreases to a certain point, known as **deadband**, the micro switch closes and starts the motor, and the pump begins to run.

Electronic—the fluid pressure is sensed electronically and the signal is sent to a circuit board and compared to the signal received by the pressure control knob. The deadband on an electronic pressure control is typically around 50 psi; thus, the pump begins to run when the pressure drops 50 psi. However, recent advances in Graco electronic controls have virtually eliminated deadband. Electronic pressure controls regulate the pressure in a manner that is constant and accurate, perfect for painting contractors who spray coatings at low pressures or who need to maintain constant spraying pressures.

SmartControl™

Graco's exclusive SmartControl, advanced microprocessor control delivers:

- A consistent spray fan at all spraying pressures.
- Zero deadband (no pulsating, steady consistent pressure) at lower spraying pressure, ideal for fine finish spraying.
- Graco's WatchDog™ System automatically shuts sprayer off when paint supply bucket is empty to prevent sprayer damage.

The primary purpose of an airless gun is to act as an on/off valve. Many spray guns have added features like built-in filters or swivels for increased performance. When choosing one gun over another, there are several factors to consider such as the size of the fluid passage and diffuser, pressure rating, as well as the comfort and feel of the gun.

Graco offers the following airless spray gun options depending on the model:

- Comfort grip form-fitted handle
- 2 or 4-finger trigger
- Built in filter in the handle
- Fluid tube made of stainless steel
- 4-finger trigger with round handle
- Trigger pull is 30% lighter than competitive guns
- Fine finish model for finer atomization
- Hose connects directly to the fluid inlet through a spring guard mounted at the base of the gun
- Thumb lock and safety trigger lock
- Built-in hose swivel connection for easier spraying

Pole Gun

Pole guns are a real time and muscle saver when spraying high or recessed areas. Graco's Pole Gun shuts fluid flow off at the tip for a crisp spray pattern with no spitting or delays. The Pole Gun is rated at 3600 psi (248 bar, 24.8 MPa) and is available in 3- and 6-foot lengths.

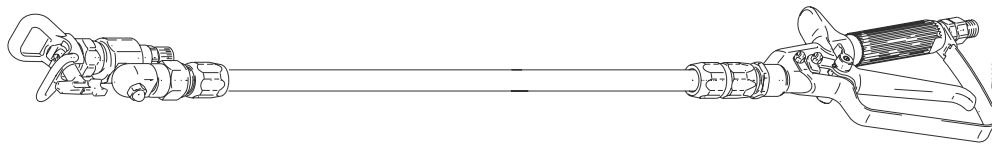

Airless Spray Hose

Airless spray hoses are available in different lengths, diameters, and pressure ratings. Selecting the proper hose is critical for maintaining optimal spraying pressure at the gun.



The length and diameter of hose you use affects the pressure drop of fluid to the spray gun. A longer hose has a greater pressure drop. A smaller hose diameter has greater pressure drop.

For ease of use, Graco hoses are now more flexible and durable.

Hose length, diameter and the resulting pressure drop should be considered when selecting the size airless sprayer to purchase.

If using two different diameter hoses coupled together, attach the larger diameter hose to the pump and the smaller hose to the gun to minimize pressure drop.

Pressure Roller

Pressure rolling is ideal when spraying is not possible. Simply pull the gun trigger when you need more paint and keep on rolling. No more climbing up and down ladders and stopping to dip the roller in a messy tray. Reach to the top without a ladder with fixed or telescoping extensions.

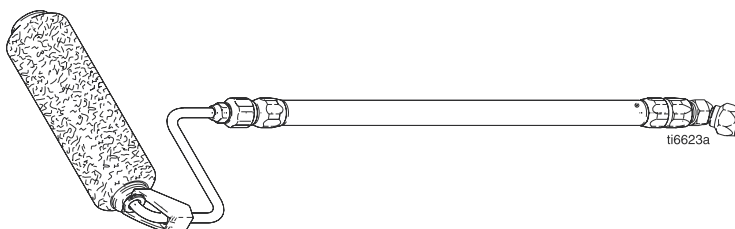

Maintaining Airless Equipment

Check your operators manual for the complete maintenance requirements of your specific Graco equipment.

Equipment Inspection

Check the following components and tighten, clean or replace, as needed:

- Inlet screen
- Manifold filter
- Gun filter
- Tip filter
- Hose connections
- Inlet suction tube
- Gun Body
- Tip guard and Tip
- Trigger safety
- Trigger guard
- Power cord

General Maintenance

- Use the appropriate size filters for the material being sprayed (see The Correct Filter Reduces Tip Clogs chart).

The Correct Filter Reduces Tip Clogs

Mesh Size	200	100	60	30
<i>Materials</i>	Stains, Varnish, Polyurethane Solvent Based	Lacquers, Enamels (Solvent), Solvent Based Paints	Latex, Enamels (Latex)	Heavy Latex, Block Filler, Elastomeric
<i>Use With Tip Sizes</i>	.007 - .013 inch	.013 - .015 inch	.015 - .029 inch	.031+ inch

- Check filters daily, if clogged more than 20%, replace. If punctured, replace immediately
- Visually check hoses every time you spray for internal build-up, cracks, kinks, holes, blisters, abrasions, and damage to the hose cover
- Use two wrenches when tightening all hose connections

- Check conductivity of hose once per quarter with an OHM meter, see manual for details. Conductivity is important to dissipate static electricity build-up at the gun
- Ensure good air-flow path into motor, wipe shroud clean after each use
- Do not cover the pump with a rag or plastic while spraying, allow good airflow to keep the sprayer cool
- Don't pressure wash the unit
- Wet cup/brass packing nut tightened. Fill cup with TSL every time you spray to reduce paint adhesion on the rod. Do not use oil as a substitute for TSL
- If raw paint appears on the pump rod, tighten packing nut 1/8 turn or until weeping stops
- When pump packings wear, paint will begin to leak down the outside of the pump. Replace pump packings at the first sign of leaking or additional damage could occur to the expensive pump hard parts
- Clear tips with a couple short bursts of water or solvent
- Clean tips with a soft brush. Store tips for short periods in a sealed container of water or solvent
- Replace tips if worn more than two tip sizes
- In cold climates, don't allow water or paint to freeze in internal parts or the hoses. Expansion as water freezes can cause severe damage
- HVLP – Check and clean or replace air intake filters
- Gas Units – Check oil level. Change oil as indicated in owners manual

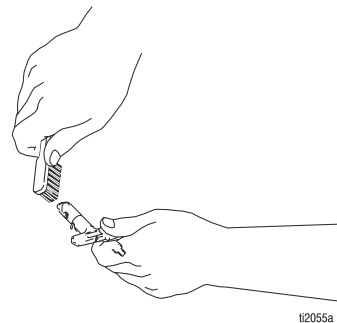
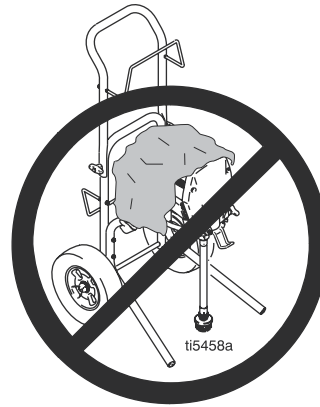

- Bring your sprayer in annually for a general service check at an authorized Graco repair center
- Do a dirty rinse and a clean rinse, another rinse with clean water or thinner, with a minimum of five gallons of rinse fluid
- Store your system with the pump rod in the down location. Less exposure to air will reduce corrosion
- Short term storage (overnight), water is OK, thinner is better
- Longer term storage, thinner is OK, Pump Armor is better
- Do not store the unit under pressure
- To prevent fluid from running out of sprayer during storage, fasten a plastic bag over suction tube when not using sprayer.

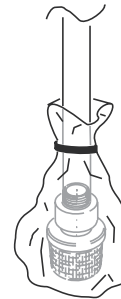

ti5552a

Safety is a shared responsibility. It is up to everyone to ensure a safe working environment.

- Graco, as a manufacturer, is responsible for providing reliable products as well as safety information
- The sales team, as representatives of Graco, should demonstrate and point out safety devices and procedures when demonstrating airless spray equipment
- Distributors and their employees are responsible for training their staff about airless spray equipment and should always follow safety procedures
- Airless spray equipment users should read all warnings and should follow all safety precautions and procedures

An effective way to become familiar with safety considerations and procedures is to review the **Instruction Manuals** that are included with Graco products. The manuals use icons to represent the different types of hazards, such as fire and explosion, toxicity, injection, and others. The icons indicate the location of safety information located throughout the instruction manuals and operating instructions.

Potential Hazards (and their icons)

The potential hazards that may occur when using Graco products are:



Fire and Explosions—can only occur if there is an ignition source combined with flammable vapors and air in the workspace. Ignition sources that can potentially lead to a fire or explosion are:

- Electrical switches or motors
- Open flames
- Static electricity

To prevent fire and explosion:

- Install and use proper ventilation
- Remove or extinguish all ignition sources, such as pilot lights, cigarettes, arcing motors, and others
- Ground all people, objects and spraying equipment in the spray area to prevent electrostatic discharge
- Use appropriate flushing procedures: use water, mineral spirits or lacquer thinner—Never use gasoline!
- Use only grounded outlets, extension cords, and fluid hoses designed for high-pressure spraying that are in good condition—do not modify or remove electrical cords.



Skin Injection—spray equipment users and doctors often underestimate the seriousness of a skin injection injury and the medical complications that could result. The injury might look like “just a cut” but should be considered a serious injury! The factors in the work environment that contribute to the risk of accidental skin injection are:

- A high-pressure fluid stream directed toward skin or clothing
- Removal of protective devices from equipment (gun safety, trigger guard, and tip guard)
- Unintended release of fluid pressure
- Failure to use a spray gun trigger safety

To prevent skin injection:

- Stay clear of high-pressure fluid streams and sprays
- Never remove protective devices, such as spray gun tip guards
- Use proper pressure-relief procedures
- Use proper flushing practices described in instruction manual
- Never try to stop leaks with your hands or body
- Always use the spray gun trigger safety when not spraying
- Don't feel for leaks with your hands or a rag

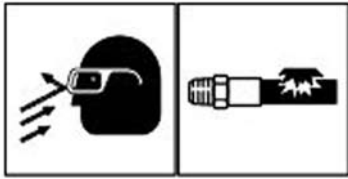

Over-pressurization and Unintended Pressure Release—pressure-related injuries occur when equipment is over-pressurized and a component of the airless sprayer ruptures. Component ruptures are most often caused by:

- Exceeding the safe working pressure of a component
- Continued use of worn or damaged equipment
- Operator does not follow pressure-relief procedures
- Using replacement parts that are not genuine Graco parts
- Connections are not tight
- Connections are incompatible
- Connections or components are inappropriate for the pressure rating

When equipment components rupture or an unexpected pressure release occurs, injuries are most often caused by spray in the face or eyes, a whipping hose, or projectiles.

To prevent pressure-related injuries

- Do not exceed the working pressure ratings (WPR) of components, paying special attention to high-pressure equipment
- Use pressure-relief devices like pressure relief valves on sprayers
- Limit the air or hydraulic pressure to the motor so that the fluid pressure produced by the pump is less than the working pressure of all system components
- Do not repair permanently coupled hoses
- Use only genuine Graco service parts
- Do not modify Graco (or any other) parts
- Properly align spray tips to prevent back-spray
- Do not use low-pressure fittings on high-pressure equipment
- Use proper pressure-relief procedures
- Do not use damaged or worn equipment
- Check for proper connections and make sure they are tight before pressurizing the system



Injury from Moving Parts—injury from moving parts most often occurs after:

- Unintended contact with moving components (for example, air motor and pump displacement rods)
- Removal of equipment guards
- Failure to completely relieve fluid and air pressure when servicing equipment

To prevent injury from moving parts:

- Follow procedures for relieving fluid pressure whenever you stop equipment for service or repair
- Never operate equipment with guards or other protective devices removed
- Check regularly to ensure that safety devices are operating properly
- Properly use bleed type shutoff valves



Toxicity—is a potential risk when:

- Fumes from coating materials, fluids, or gas engine exhaust fumes are present in the work environment
- Toxic fluid makes contact with skin, nose, mouth, or eyes

To prevent toxicity:

- Use recommended personal protection equipment (PPE) to avoid contact with hazardous materials
- Read and follow directions on all coating material labels and **material safety data sheets** (MSDS)
- Follow the recommendations of fluid manufacturers
- Never operate gas engines indoors



Electric Shock—the factors in the work environment that may potentially lead to electric shock are:

- Contact with electrically live or charged parts
- Improper grounding of equipment and other objects in the spray area

To prevent electric shock:

- Properly ground all objects in the system, including operators
- Follow the procedures in instruction manuals to avoid shocks from electrostatically charged components
- Never operate electric equipment when it is wet or when the surrounding area is wet
- Use only grounded outlets, extension cords, and fluid hoses designed for high-pressure spraying that are in good condition
- Do not modify or remove electrical cords.



The instruction manual for each Graco product identifies preventive actions that pertain to that equipment. Always consult the product safety information in the manual to learn about the safe use of each Graco product.

Beyond the Basics . . . Accident & Near Miss Reporting

All Graco employees and distributors must report accidents and near-miss accidents to Graco toll free at **1-800-543-0339**. Prepare for the possibility of an accident by having the **Graco Accident Reporting Wallet Card** on hand at all times. **To order the Graco Accident Reporting Wallet card, call customer service, toll free at 1-800-690-2894 and order part number 301-283.**

	ACCIDENT AND "NEAR MISS" REPORTING PROCEDURE
If you hear about an accident or "near miss" which might have involved a Graco product, immediately call GRACO TECHNICAL ASSISTANCE toll free at 800-543-0339 . An accident is when someone or something <u>may have been</u> injured or damaged. A "near miss" is when someone or something <u>could have been</u> injured or damaged.	
If in doubt, CALL.	
CALL EVEN IF:	If possible, give this information to Tech Assistance:
<ul style="list-style-type: none">• the Graco product might not have been the cause.• the injury or damage appears to be minor or not permanent.• the product(s) might not be Graco product.	<ul style="list-style-type: none">• the name, address and telephone number of the company using the Graco product.• the Graco product(s) involved.• the date of the accident or "near miss".• a brief description of what happened.
	301-283

Important!

An injection occurs when high-pressure fluid pierces the skin. The injury might look like "just a cut" but should be considered a serious injury!

Any injury caused by high-pressure fluid can be serious. If you or someone else becomes injured -- even slightly:

- *Go immediately to an emergency room*
- *Notify the doctor that the injury is a "fluid injection injury"*
- *Be sure to tell the doctor the type of material that was injected.*

Atomization: fluids under high pressure when forced at high velocity through a small orifice (hole) break up into very small droplets. If the hole is elliptically shaped (like a “cats eye”), as in the case of many airless spray tips, the spray pattern produces an ellipse-shaped paint deposit.

Air Spray: atomization is achieved by directing small streams of compressed air into the stream of paint or other coating. This action blows the fluid stream into many small droplets and causes a turbulent cloud of droplets to be formed—normally this results in a fine finish.

Blow-by: when the paint spray fan reaches the end of a surface, such as an outside corner, and the fan continues beyond the surface, paint is “blown-by” the target surface in a cloud of droplets.

Bounce-back or Back-spray: when the painter directs the airless spray fan at the surface, sometimes the droplets will rebound from the surface. This is the result of excessive pressure and excessive velocity beyond the amount needed to atomize the coating.

Commercial jobs: when used in conjunction with painting contractor jobs, refers to non-manufacturing and non-residential buildings such as office space, schools, motels/hotels, apartments and hospitals.

Deadband: the difference between the pressures at which the pump turns on and off. In airless sprayers there may be ranges of pressure in which the amount of pressure cannot be regulated. The “deadband” or non-regulated ranges of pressure can vary depending on the type of airless sprayer and the pressure control device being used. Less deadband means more consistent pressure and a better spray pattern.

Diaphragm: a pump design that uses a circular or oblong flexible synthetic membrane, sealed at its outer edges and connected in its middle to a reciprocating rod (or motor rod) or pulsating hydraulic fluid. As the membrane moves in response to the rod or hydraulic fluid, fluid is loaded and dispensed through the check valves.

Electronic Pressure Control: a pressure regulation device that uses electronic components, rather than electric or mechanical components, to provide precise pressure regulation.

Fingers or Tails: terms used to describe spray patterns that are not consistent or that are uneven.

HVLP-like Pattern: high volume low pressure (HVLP) spray technology provides soft pattern edges and fine droplet size, and gives a fine finish spray pattern. Airless spraying using Fine Finish spray tips, combined with electronic pressure controls and low pressure, can provide an HVLP-like pattern.

Industrial jobs: professional painting contractors consider projects such as manufacturing plants, tank farms, refineries and bridges/dams as industrial jobs.

Injection: because fluid is under high pressure when it leaves an airless spray tip/gun, if the fluid stream pierces the human skin it is called “injection.” This must be regarded as a serious injury and requires immediate medical attention.

Mil Build: the thickness of the coating during or after spraying.

Overspray: when paint or other coatings are atomized, the tiny droplets form a cloud that may go beyond the edges of anything being sprayed.

Pressure Drop: the drop in pressure caused by restriction of flow due to conduits such as pipes, hoses, valves, and so forth. As flow rate increases so does the pressure lost to resistance of flow within a given device. Decreasing the restriction, such as increasing the diameter of the hose will reduce the pressure drop. Usually the higher the viscosity of the coating materials, the higher the pressure drop.

Priming the Pump: when fluid is pumped into the dry chambers of the pump so that it can begin to displace the fluid.

Residential: usually considered to be single or multi-family residential housing. Some professional painting contractors consider small apartment buildings, condominiums, and town houses to be residential spraying jobs.

Shadows: when spraying a textured surface the pattern might not fully coat the entire surface. Shadows are overcome by spraying the surface from the opposite direction filling in the shadowed areas.

Skips: an absence of paint on a newly painted surface. Also called “holidays” or “voids”.

Substrate: the surface that is being painted.

Tungsten Carbide: the most abrasive resistant material used in manufacturing airless spray tips.

Viscosity: is the resistance of a fluid to flowing. Thus, the more a fluid resists flowing, the higher its viscosity. To move a fluid, its viscosity must be overcome. Since the purpose of Graco products is to move fluids, viscosity is the most important fluid property to consider when you are recommending Graco products. The viscosity of a given fluid depends on several factors; however, the most important of these factors is temperature. The viscosities of most fluids decrease as their temperatures increase.

Voltage Brownout: excessive current draw on an electrical power line. AC motors, which are negatively affected, will begin to overheat and some switches may fail to operate.



ABOUT GRACO

PROVEN QUALITY. LEADING TECHNOLOGY.

Founded in 1926, Graco is a world leader in fluid handling systems and components. Graco products move, measure, control, dispense and apply a wide range of fluids and viscous materials used in vehicle lubrication, commercial and industrial settings.

The company's success is based on its unwavering commitment to technical excellence, world-class manufacturing and unparalleled customer service. Working closely with qualified distributors, Graco offers systems, products and technology that set the quality standard in a wide range of fluid handling solutions. Graco provides equipment for spray finishing, protective coating, paint circulation, lubrication, and dispensing sealants and adhesives, along with power application equipment for the contractor industry. Graco's ongoing investment in fluid management and control will continue to provide innovative solutions to a diverse global market.

GRACO LOCATIONS

MAILING ADDRESS

P.O. Box 1441
Minneapolis, MN 55440-1441
Tel: 612-623-6000
Fax: 612-623-6777

AMERICAS

MINNESOTA

Worldwide Headquarters
Graco Inc.
88-11th Avenue N.E.
Minneapolis, MN 55413

EUROPE

BELGIUM

European Headquarters
Graco N.V.
Industrieterrein-Oude Bunders
Slakweidestraat 31
3630 Maasmechelen,
Belgium
Tel: 32 89 770 700
Fax: 32 89 770 777

ASIA PACIFIC

AUSTRALIA

Graco Australia Pty Ltd
Suite 17 2 Enterprise Drive
Bundoora Victoria 3083
Australia
Tel: 61 3 9467 8558
Fax: 61 3 9467 8559

CHINA

Graco Hong Kong Ltd.
Shanghai Representative
Office
Room 118 1st Floor
No.2 Xin Yuan Building
No.509 Cao Bao Road
Shanghai, P.R. China 200233
Tel: 86 21 649 50088
Fax: 86 21 649 50077

INDIA

Graco Hong Kong Ltd.
India Liaison Office
Room 103, Level 4, Augusta Point
Golf Course Road
Gurgaon, Haryana, India 122001
Tel: +91 124 435 4208
Fax: +91 124 435 4001

JAPAN

Graco K.K.
1-27-12 Hayabuchi
Tsuzuki-ku
Yokohama City, Japan 2240025
Tel: 81 45 593 7300
Fax: 81 45 593 7301

KOREA

Graco Korea Inc.
Choheung Bank Building
4th Floor #1599
Gwanyang-Dong, Dongan-Ku,
Anyang-Si, Gyeonggi-Do,
Korea 431-060
Tel: 82 31 476 9400
Fax: 82 31 476 9801

SALES/ DISTRIBUTION/ SERVICE

Call today for product information or to request a demonstration.

800-690-2894 or visit us at www.graco.com.

Graco Inc. is registered to I.S. EN ISO 9001

North America
Customer Service
800-690-2894
Fax 800-334-6955